

pro.IQ moisture transmitter packaged solution

Features

pro.IQ simplifies the selection and installation of your moisture transmitter for a complete moisture measurement solution. Only a few simple steps; install the moisture transmitter, connect your loop power and sample gas to the inlet fitting and you are ready to measure. Includes:

- IP66 & NEMA 4X package
- The moisture transmitter, sample system and Zener barrier (if hazardous area option selected)
- Features the HygroPro moisture transmitter
- Sample system to provide isolation, filtration, pressure and flow indication, with a clear door for easy viewing of all readings

Applications

The standard pro.IQ package is designed for moisture measurements in any hydrocarbon gas or inert gas application. It may be used in environments classified as safe or hazardous areas, where the process gas pressure is up to 200 psig (14 bar) in safe area and 400 psig (27 bar) in hazardous area. The system combines the Panametrics HygroPro with 50 years of sample system design experience, to deliver the moisture measurement you have come to trust.

Markets and applications served include:

- Natural gas
- Hydrocarbon gases
- Petrochemical
- Metal heat treatment
- Industrial gas
- Power generation

Ordering configuration

pro.IQ is comprised of the following items:

- HygroPro moisture transmitter
- Sample system 733-2500 or 733-2501 or 733-2502 or 733-2503 dependent on version selected
- Zener Barrier (Hazardous area option only)

Available versions

- pro.IQ-H-I : Hazardous Area, ¼" Tube Fittings
- pro.IQ-H-M : Hazardous Area, 6mm Tube Fittings
- pro.IQ-GP-I : General Purpose Area, ¼" Tube Fittings
- pro.IQ-GP-M : General Purpose Area, 6mm Tube Fittings

Application parameters

General purpose configuration

- Sample Gas Pressure: 0 to 200 psig (14 bar)
- Recommended Operating Temperature Range: 32°F to 122°F (0 to +50°C)

Hazardous area configuration

- Sample Gas Pressure: 0 to 400 psig (27 bar)
- Recommended Operating Temperature Range: 32°F to 122°F (0 to +50°C)

Common

- Moisture Content: 68°F to -166°F (20°C to -110°C) dew/frost point, non-condensing

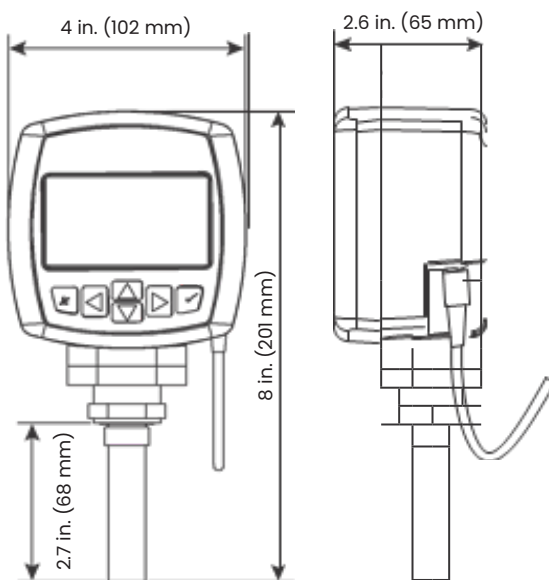

HygroPro dimensions

HygroPro specifications

Dew point/frost point calibration ranges

- Overall: 68°F to -166°F (20°C to -110°C)
- Standard: 68°F to -112°F (20°C to -80°C)

Operating temperature

-4°F to 140°F (-20°C to 60°C*)

*Refer to pro.IQ specifications for overall system limits

Storage temperature

158°F (70°C) maximum

Warm-up time

Meets specified accuracy in three minutes

Calibrated accuracy @ 77°F (25°C)

- ±3.6°F (±2°C) above -148°F (-100°C)
- ±5.4°F (±3°C) below -148°F (-100°C)

Repeatability

- ±0.4°F (±0.2°C) above -148°F (-100°C)
- ±0.9°F (±0.5°C) below -148°F (-100°C)

Electrical

Power

- Voltage: 12 to 30 VDC (loop-powered, customer supplied)
- Output: 4 to 20 mA analog, RS485 digital
- Output Resolution: 0.01 mA/12 bits
- Load: Max R = (PSV x 33.33) - 300
Example: (24 x 33.33) - 300 = 500 W
- Cable: 1.5 ft (0.5m), standard includes molded M8 connector with flying leads to connect transmitter to sample system terminal block

Display

- 128 x 64 LED backlit LCD
- Display from one to three parameters and diagnostics

Mechanical

Sample connection

- 3/4-16 in. (19 mm) straight male thread with O-ring

Operating pressure

5 mHg to 5000 psig (345 bar*)

*Refer to pro.IQ specifications for overall system limits

Enclosure

Type 4X/IP67

Dimensions

- H x W x D: 7.88 x 3.99 x 2.56 in. (200 x 101 x 65 mm)
- Weight: 1.2 lb (550 g)

European compliance

Complies with EMC Directive 2004/108/EC and PED 97/23/EC for DN<25

Hazardous area certification

- C-US Class I, Division 1, Groups A,B,C&D, Type 4X
-  1 G Ex ia IIC T4 (ATEX)
- Ex ia IIC T4 (IEC Ex)

Moisture sensor

Sensor type

Thin-film aluminum oxide moisture sensor

Calibration

Each sensor is individually computer-calibrated against known moisture concentrations, traceable to International Standards.

Calibration interval

Sensor recalibration by Panametrics is recommended every six to twelve months depending on application.

Flow rate

Gases: Static to 100 m/s linear velocity at 1 atm

Built-in temperature sensor

Type

NTC thermistor

Operating range

-22°F to 158°F (-30°C to 70°C)

Accuracy

±0.9°F (±0.5°C) overall

Response time (maximum)

One second in well stirred oil or 10 seconds in still air for a 63% step change in increasing or decreasing temperature

Built-in pressure sensor

Type

Solid state/piezoresistive

Available ranges for pro.IQ

- 30 to 300 psig (3 to 21 bar)
- 50 to 500 psig (4 to 35 bar)

Accuracy

±1% of full scale (FS)

Pressure rating

Three times the span of the specified range to a maximum of 7500 psig (518 bar*)

*Refer to pro.IQ specifications for overall system limits

NOTES

1. PROCESS CONNECTIONS: 1/4" OR 6mm TUBE FITTINGS.
2. DIMS : INCH [MM]
3. APPROX WEIGHT : 33LBS [15KG]
4. SIGNAL CONNECTIONS : 1/2" NPTF HUB WITH CABLE GLAND (IMPERIAL VERSION)
M20 CABLE GLAND (METRIC VERSION)
5. ENCLOSURE DEPTH : 6.82 [173]
6. COMPONENTS SELECTED FOR : CLASS I, DIV.1, GROUPS A-D, T4 (H VERSION)
ATEX/IECEx ZONE 0 IIC T4 (H VERSION)
GENERAL PURPOSE AREA (GP VERSION)
7. RECOMMENDED OPERATING TEMP: +32°F to +122°F (0°C to +50°C)
8. MTL7706 BARRIER SUPPLIED WITH HAZ AREA VERSIONS ONLY
9. AVAILABLE VERSIONS:
pro.io-H-I : HAZARDOUS AREA, 1/4" TUBE FITTINGS
pro.io-H-M : HAZARDOUS AREA, 6mm TUBE FITTINGS
pro.io-GP-I : GENERAL PURPOSE AREA, 1/4" TUBE FITTINGS
pro.io-GP-M : GENERAL PURPOSE AREA, 6mm TUBE FITTINGS

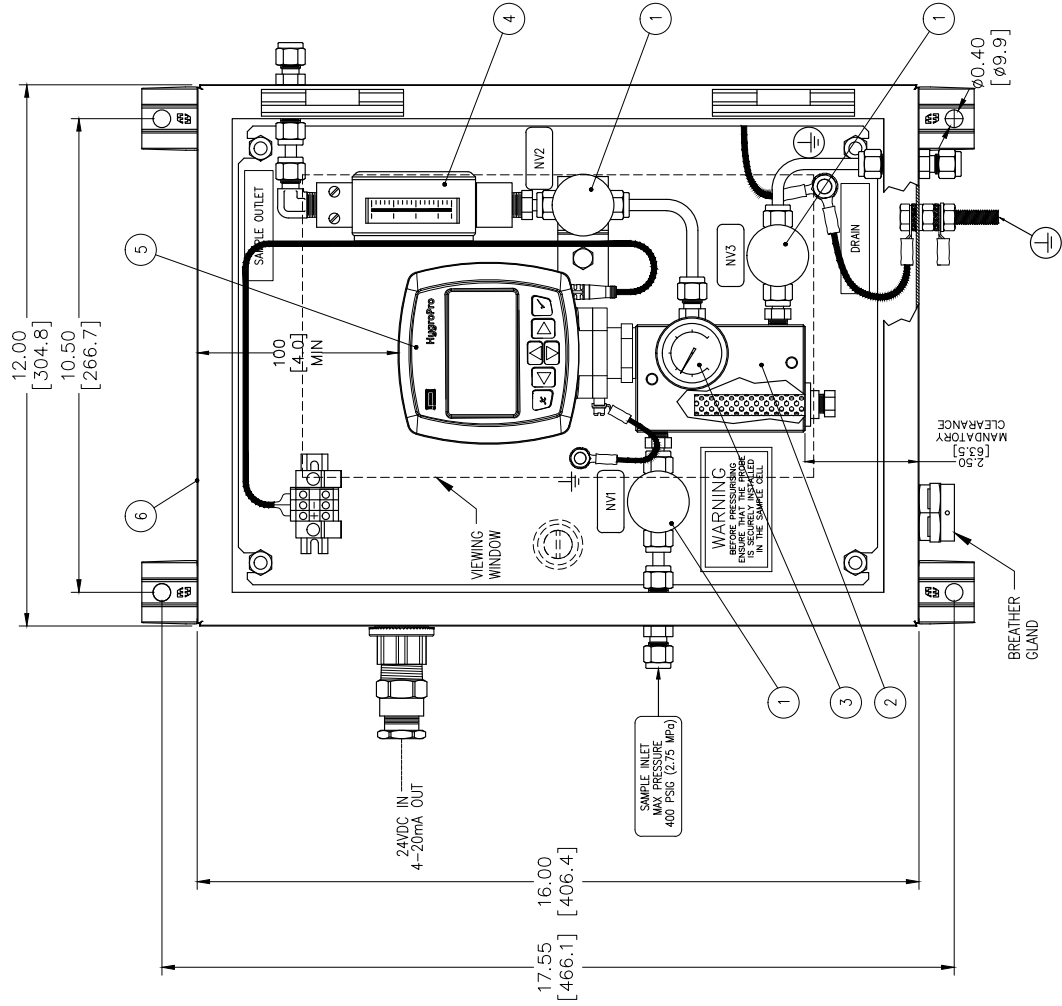

BILL OF MATERIAL

ITEM	DESCRIPTION	QTY
1	NEEDLE VALVE 316SS	3 *
2	SAMPLE CELL MANIFOLD WITH FILTER	1
3	PRESSURE GAUGE SS	1
4	FLOWMETER 316SS (INTEGRAL VALVE ON GP VERSION)	1
5	HYGROPRO MOISTURE TRANSMITTER	1
6	304SS ENCLOSURE WITH PAINTED PLATE RAL6033	1

* 2 x NEEDLE VALVES ON GENERAL PURPOSE VERSIONS

Start-up procedure

- Insert moisture transmitter into the sample cell and connect earth to ground connection of the transmitter
- Follow HygroPro manual wiring instructions to connect power, and zener barrier installation and wiring if in hazardous area
- Two filter elements are provided. Sintered steel for clean gases and liquids. Fiber for gases with entrained liquids or aerosols. Install the filter element most appropriate for the application
- Start with the inlet valve NV1, the drain valve NV3 and the sample outlet valve NV2 fully closed
- For measurement at process pressure, slowly turn the inlet valve NV1 until fully open; then crack the sample outlet valve NV2 to get flow on mid range of the flowmeter scale
- For measurement at atmospheric pressure, fully open the sample outlet valve NV2; then crack the inlet needle valve NV1 to get flow on scale
- For applications with potential light liquid contaminant crack the drain needle valve NV3 to ensure continuous removal of any liquid mists from the sample gas



Shut-down procedure

- Slowly close the inlet needle valve NV1
- Close outlet needle valve NV2 fully
- Slowly open the drain needle valve NV3 until the pressure on the pressure gauge is 0 psig
- Remove the moisture transmitter